



# Flange Isolation Catalog

*Sealing and Isolating Gaskets*

*Flange Isolation Kits*

*Isolation Sleeves and Washers*



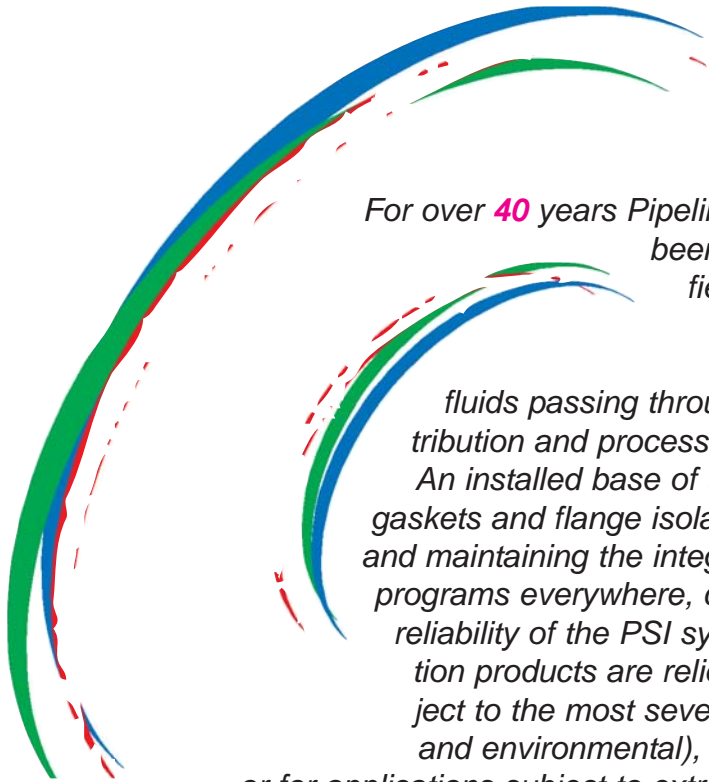

For over **40** years Pipeline Seal and Insulator, Inc. has been a technology leader in the field of high quality sealing and isolating products used to guarantee the safe flow of fluids passing through pipeline transmission, distribution and process piping systems.

An installed base of thousands upon thousands of gaskets and flange isolation kits, effectively sealing and maintaining the integrity of corrosion mitigation programs everywhere, confirms the effectiveness and reliability of the PSI system. In fact, PSI flange isolation products are relied upon for applications subject to the most severe conditions (both internal and environmental), for specialized or exotic fluids or for applications subject to extreme temperature and pressure fluctuations.

Flange isolation products include a wide selection of isolating/sealing gaskets along with a variety of sleeves and washers. For maximum flexibility, components may be ordered separately or as part of complete flange isolation kits.

Manufacturing facilities are located in the United States and Europe, with sales and service facilities located worldwide. All PSI facilities are ISO 9001:2000 certified with extensive quality control procedures to insure total compliance with product performance and reliability standards.

Additions to the PSI line of flange isolation products are the LineBacker Zero™ sealing gasket, LineBacker 250™ sealing gasket and LineBacker 251™ sealing gasket, all designed to address problems associated with asbestos substitutes and fugitive emissions. This catalog includes suggested flange isolation material compatibility charts as well as technical specifications and an ordering/work sheet.

# PSI Isolating Gasket Types and Styles

## Type “E” Gaskets

Type “E” Gaskets extend to the outside diameter of the flange. They feature precision located bolt holes, to automatically center the gasket, and offer maximum protection against foreign material “shorting-out” the flange.

Type “E” gaskets may be ordered in any one of the following configurations:

- LineBacker® Sealing Gaskets
- GasketSeal® Sealing Gaskets
- **Rubber** Faced Phenolic Gaskets
- Plain Phenolic Gaskets
- Red Devil Gaskets
- Yellow Jacket Gaskets
- Garlock Gaskets
- Teflon® Gaskets

When configured as a LineBacker® Sealing Gasket, the sealing element may be positioned anywhere between the I.D. of the gasket and I.D. of the bolt circle.

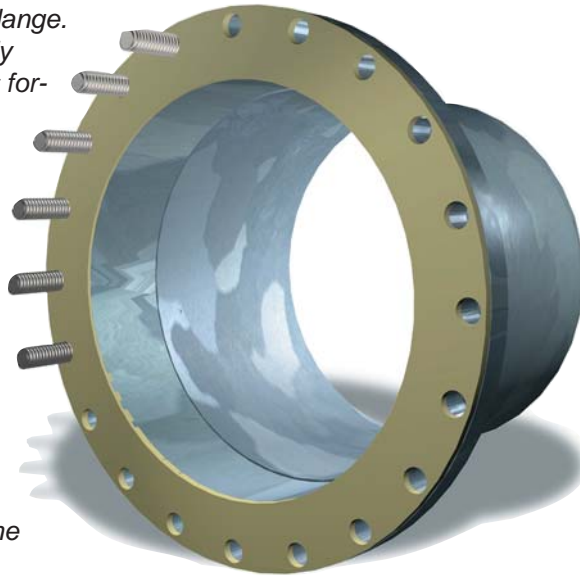

## Type “F” Gaskets

Type “F” Gaskets are made to fit within the bolt hole circle of the flange.

The O.D. of the gasket extends out to the I.D. of the bolt hole circle for good protection against foreign material “shorting-out” the flange. When configured as a LineBacker® Sealing Gasket, the sealing element may be positioned anywhere between the I.D. and O.D. of the gasket.

Type “F” gaskets may be ordered in any one of the following configurations:

- LineBacker® Sealing Gaskets
- GasketSeal® Sealing Gaskets
- **Rubber** Faced Phenolic Gaskets
- Plain Phenolic Gaskets
- Red Devil Gaskets
- Yellow Jacket Gaskets
- Garlock Gaskets
- Teflon® Gaskets

When configured as a LineBacker® Sealing Gasket, the sealing element may be positioned anywhere between the I.D. of the gasket and I.D. of the bolt circle.

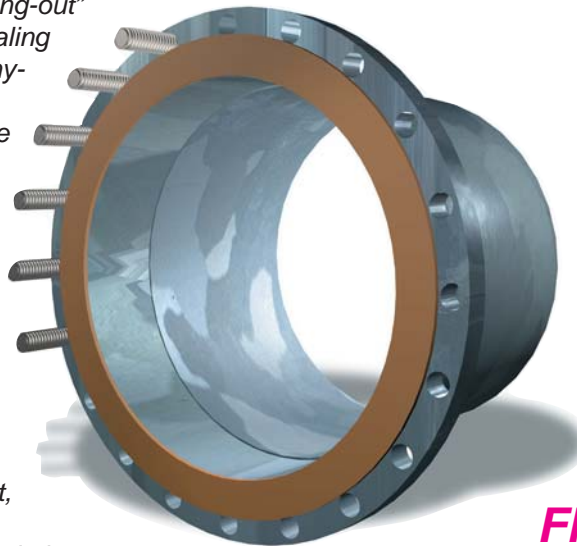

## Flange Faces



## Type “D” Gaskets

Type “D” Gaskets are available for RTJ flanges but the LineBacker® Sealing Gasket is an excellent alternative to “D” gaskets because the sealing element may be positioned anywhere between the I.D. of the gasket and I.D. of the ring groove.

**Flange Faces >25 Micro Inches**  
For flange face surfacing greater than  
25 micro inches, consult factory.

# PSI Isolating Gaskets - Standard 1/8" Thick

## GasketSeal<sup>®</sup> Sealing Gaskets



After Tightening

GasketSeal<sup>®</sup> sealing gaskets are considered one of the most effective methods for sealing and isolating flanges of all types. The gasket consists of two molded semi "O" rings (with precise crown to void ratio) mounted in grooves on opposite sides of an isolating retainer. While maintaining all the advantages of a full "O" ring seal, the semi "O" ring seal eliminates the need for a sealing groove in the flange face to reduce problems associated with alignment. **GasketSeal<sup>®</sup> gaskets are self energizing with theoretical near zero "m" and "y" factors resulting in effecting a positive seal without excessive bolt loads required with flat gaskets.** GasketSeal<sup>®</sup> sealing gaskets are available in a wide variety of retainer and sealing element combinations for matching gaskets to service and environmental conditions. Refer to the chart for the GasketSeal<sup>®</sup> sealing gasket temperature ranges and material compatibilities. **Note: Flange Faces, see page 3.**



## LineBacker<sup>®</sup> Sealing Gaskets



After Tightening

LineBacker<sup>®</sup> sealing gaskets utilize a patented rectangular sealing element, referred to as a "quad" ring, in combination with a unique groove design to effectively seal and isolate flanges of all types. With the unique "quad" ring design, elastic memory is provided for elastomers not normally associated with this characteristic. Materials such as **AFLAS**, TFE (Teflon) and **KALREZ** may therefore be used as sealing elements which dramatically increases the options available for matching gasket materials to service and environmental conditions. This greater variety of materials also provides excellent temperature and chemical range compatibility. LineBacker<sup>®</sup> sealing gaskets are self energizing with theoretical near zero "m" and "y" factors resulting in effecting a positive seal without excessive bolt loads required with flat gaskets. Refer to chart for LineBacker<sup>®</sup> sealing gasket temperature range and material compatibilities. **Note: Flange Faces, see page 3.**

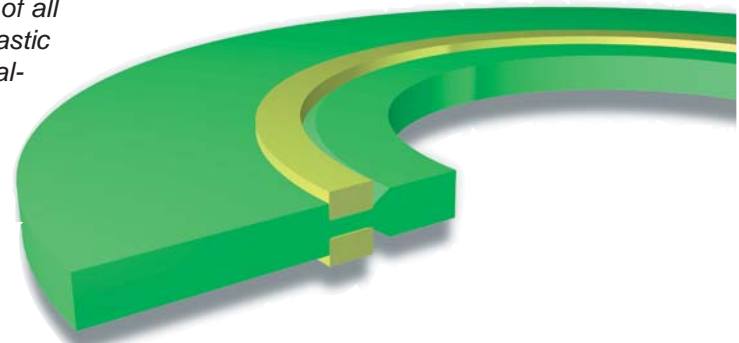

## Rubber Faced Phenolic Gaskets

Rubber Faced Phenolic gaskets have been used as standard "flat" isolating gaskets in the oil and gas industries for many years. Soft neoprene rubber sheets are factory applied to both sides of a laminated phenolic retainer providing an effective sealing surface. The temperature limit of these gaskets is approximately +175° F. (80° C.). **Note: Due to improved sealing characteristics and retainer/seal element options, LineBacker or GasketSeal sealing gaskets should be considered in lieu of rubber faced phenolic gaskets whenever possible.**

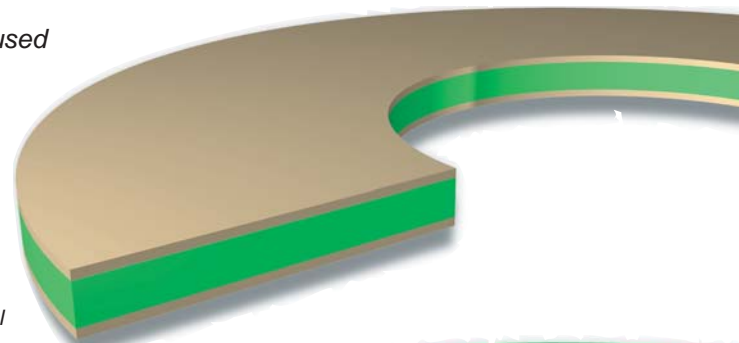

## Flat Gaskets

Flat gaskets are used in special applications such as elevated temperatures that often require materials such as Red Devil or Yellow Jacket. Please contact a PSI representative for additional information on available options.



## Suggested Flange Isolation Material Compatibility

| Medium               | Retainer        | Seal              | Sleeve | Washer           | Temp. Range °F | Temp. Range °C |
|----------------------|-----------------|-------------------|--------|------------------|----------------|----------------|
| Acetone              | Phenolic        | EPDM              | Mylar  | Phenolic         | +32 to +80     | 0 to +27       |
| Air                  | G-10            | Nitrile           | Mylar  | Phenolic         | -40 to +225    | -40 to +107    |
| Ammonia Dry          | G-10            | Teflon            | Mylar  | G-10             | -65 to +220    | -54 to +104    |
| Ammonia (Wet)***     | G-10            | Teflon            | Mylar  | G-10             | +32 to +100    | 0 to +38       |
| Bleach               | G-10            | Teflon            | Mylar  | G-10             | +32 to +80     | 0 to +27       |
| Butylene (Butadiene) | G-10            | Teflon            | G-10   | G-10             | +32 to +100    | 0 to +38       |
| Carbon Dioxide       | G-10            | Nitrile           | Mylar  | G-10             | +32 to +150    | 0 to +66       |
| Caustic Soda (NaOH)  | CONSULT FACTORY |                   |        |                  |                |                |
| Cryogenic            | G-10            | Teflon            | G-10   | G-10             | -300 to +280   | -184 to +138   |
| Ethanol              | G-10            | EPDM              | Mylar  | G-10             | +32 to +100    | 0 to +38       |
| Ethylene (Ethene)    | G-10            | Teflon            | G-10   | G-10             | +32 to +80     | 0 to +27       |
| Fuel Oil             | G-10            | Viton             | Mylar  | G-10             | -20 to +280    | -29 to +138    |
| Gas, Natural         | Phenolic        | Nitrile           | Mylar  | Phenolic         | -40 to +220    | -40 to +104    |
| Gas, Sour            | G-10            | Viton             | Mylar  | Phenolic         | -20 to +220    | -29 to +104    |
| Gasoline             | G-10            | Teflon            | Mylar  | G-10             | -65 to +225    | -54 to +107    |
| Hydrogen             | G-10            | Nitrile           | Mylar  | G-10             | -40 to +250    | -40 to +121    |
| Jet Fuel             | G-10            | Viton             | Mylar  | G-10             | -20 to +225    | -29 to +107    |
| LNG                  | G-11            | Teflon            | G-10   | G-10             | -300 to +100   | -184 to +38    |
| Mercaptan            | G-10            | Teflon            | G-10   | G-10             | -20 to +80     | -29 to +27     |
| Methanol             | G-10            | Teflon            | Mylar  | G-10             | +32 to +100    | 0 to +38       |
| MTBE                 | G-10            | Special Nitrile   | G-10   | G-10             | +32 to +80     | 0 to +27       |
| Nitrogen             | Phenolic        | Nitrile           | Mylar  | Phenolic         | -40 to +220    | -40 to +104    |
| Oil, Crude           | G-10            | Viton             | Mylar  | G-10             | -20 to +280    | -29 to +138    |
| Oxygen**             | G-10            | Teflon            | G-10   | G-10             | -65 to +250    | -54 to +121    |
| Pentane              | G-10            | Teflon            | G-10   | G-10             | +32 to +80     | 0 to +27       |
| Propane              | G-10            | Nitrile or Teflon | G-10   | G-10             | +32 to +80     | 0 to +27       |
| Propylene            | G-10            | Viton             | G-10   | G-10             | +32 to +80     | 0 to +27       |
| Sewage               | G-10            | Viton             | Mylar  | G-10             | -20 to +280    | -29 to +138    |
| Spent Liquor         | G-10            | Teflon            | G-10   | G-10             | +32 to +100    | 0 to +38       |
| Steam                | CONSULT FACTORY |                   |        |                  |                |                |
| Styrene              | G-10            | Teflon            | G-10   | G-10             | +32 to +80     | 0 to +27       |
| Sulphur (Molten)     | G-10            | Teflon            | G-10   | G-10             | +32 to +280    | 0 to +138      |
| Toluene              | G-10            | Viton or Teflon   | G-10   | G-10             | +32 to +150    | 0 to +66       |
| Water (hot)          | G-10            | EPDM              | Mylar  | G-10             | +175 to +280   | +79 to +138    |
| Water (Potable)      | G-10            | EPDM              | Mylar  | G-10 or Phenolic | +32 to +280    | 0 to +138      |
| Water (Sea)          | G-10            | EPDM              | Mylar  | G-10 or Phenolic | +32 to +280    | 0 to +138      |
| White Liquor         | G-10            | Teflon            | G-10   | G-10             | +80 to +280    | +27 to +138    |

\*\* = These are organic materials that will feed a fire if a leak occurs and an ignition source exists.

\*\*\* = Ammonia (wet) - Data to +100°F (+38°C) only (same materials as dry).

For pipe diameters over 24" or ANSI Class pressure ratings of 600# or greater, use **G-10 sleeves and G-10 washers** where temperatures and other conditions permit.  
General Note:

The foregoing performance data are intended as guidelines only. Performance suitability for any specific applications should be determined by the user.

Variation in temperature, pressure, concentration or mixtures acting synergistically may preclude suggested service use.

Material selection is at the sole risk of the user. Consult with a specialist or PSI factory for specific applications.

PSI's responsibilities will be limited to those listed in the PSI standard warranties.

# Sleeves and Washers

## Isolating Sleeves

Isolating sleeves are available in the following materials:

- Mylar
- Polyethylene
- Phenolic
- Nomex®
- G-7 Silicon Glass
- G-10 Epoxy Glass
- G-11 Epoxy Glass

Designed to easily fit over standard size flange bolts/studs within standard size bolt holes, PSI isolating sleeves have a wall thickness of 1/32" (0.79mm) and are used with separate isolating and steel washers. They are available for standard American bolt sizes from 1/2" (12.7mm) to 3-1/2" (88.9mm) as well as metric bolt sizes from 12mm and larger.

## Isolating Washers - Standard 1/8" Thick

Isolating washers are available in the following materials:

- High Strength Glass Clad Phenolic
- G-3 High Temp. Phenolic
- G-7 Silicon Glass
- G-10 Epoxy Glass
- G-11 Epoxy Glass

Designed to provide tough, positive isolation. PSI isolating washers are available for bolt sizes from 1/2" (12.7mm) through 3-1/2" (88.9mm) and are made to fit over the isolating sleeves.



## One-piece Sleeves and Washers

Molded from acetal resin and available for bolt diameters from 1/2" to 1-1/2" (12.7 to 38.1mm), one-piece sleeves and washers are structurally tough but limited to applications where the flange temperature does not exceed +180°F (+80°C) and compressive loads do not exceed 18,000 psi.

They are generally used as single washer sets because they're molded to specific lengths and, in many instances, are longer than the thickness of a single flange. A washer centering ring positions the steel washer on the unit properly to avoid uneven pressures on the washers.

**Note:** G-10 One-Piece sleeve/washer assembly available for additional strength and convenience.

## Steel Washers

Steel washers are designed to fit over the isolating sleeve or the retainer ring on the one-piece sleeves and washers. The outside diameter is sized to fit within the bolt facing on ANSI standard flanges. They are made of 1/8" (3.2mm) thick plated hot-rolled steel.



**Custom Fabricated:** G-10 One-Piece Completely Assembled - No Loose Parts.

## Sleeve Material Physical Properties

| ASTM Test Method                                   | Poly-ethylene | Mylar       | Nomex       | Phenolic    | G-7*<br>Silicone<br>Glass | G-10<br>Epoxy<br>Glass | G-11<br>Epoxy<br>Glass | One-piece<br>Molded<br>Acetal |
|--|---------------|-------------|-------------|-------------|---------------------------|------------------------|------------------------|-------------------------------|
| D149 Dielectric Strength<br>Volts/Mil (Short Time) | 400           | 4000        | 400         | 400         | 350                       | 400                    | 400                    | 1,200                         |
| D695 Compressive Strength<br>psi                   | N/A           | N/A         | N/A         | N/A         | N/A                       | N/A                    | N/A                    | 18,000                        |
| D229 Water Absorption<br>%                         | 0.01          | 0.8         | N/A         | 1.6         | 0.10                      | 0.10                   | 0.10                   | 0.22                          |
| Operating Temp.<br>°F                              | -30 to +180   | -75 to +300 | -65 to +450 | -20 to +225 | Cryogenic<br>to +450      | Cryogenic<br>to +280   | Cryogenic<br>to +320   | -30 to +180                   |
| °C   | -34 to +82    | -59 to +149 | -54 to +232 | -29 to +107 | Cryogenic<br>to +232      | Cryogenic<br>to +138   | Cryogenic<br>to +160   | -34 to +82                    |
| D790 Flexural Strength<br>psi                      | 7,000         | 13,000      | 20,000      | 16,000      | 20,000                    | 55,000                 | 55,000                 | 1,400                         |
| Cut Through Resistance<br>ft-lbs.                  | 1,800         | 3,500       | 4,000       | No Test     | No Test                   | 16,000                 | No Test                | 3,400                         |

\* = G-7 material should not be used with hydrocarbons, not even trace amounts.

## 1/8" Washer Material Physical Properties

| ASTM Test Method                                   | Glass Clad<br>Phenolic | G-3 Hi-Temp<br>Phenolic<br>Glass | G-7*<br>Silicone<br>Glass | G-10<br>Epoxy<br>Glass | G-11<br>Epoxy<br>Glass | One-piece<br>Molded<br>Acetal |
|--|------------------------|----------------------------------|---------------------------|------------------------|------------------------|-------------------------------|
| D149 Dielectric Strength<br>Volts/Mil (Short Time) | 500                    | 550                              | 350-400                   | 550                    | 550                    | 1,200                         |
| D695 Compressive Strength<br>psi                   | 33,000                 | 50,000                           | 40,000                    | 50,000                 | 50 - 80,000            | 18,000                        |
| D229 Water Absorption<br>%                         | 1.6                    | 0.7                              | 0.07                      | 0.10                   | 0.10                   | 0.22                          |
| Operating Temp<br>°F                               | -65 to +300            | -65 to +392                      | Cryogenic<br>to +450      | Cryogenic<br>to +280   | Cryogenic<br>to +350   | -30 to +180                   |
| °C   | -54 to +149            | -54 to +200                      | Cryogenic<br>to +232      | Cryogenic<br>to +138   | Cryogenic<br>to +177   | -34 to +82                    |

\* = G-7 material should not be used with hydrocarbons, not even trace amounts.

**Full length sleeve, single washer set configuration**

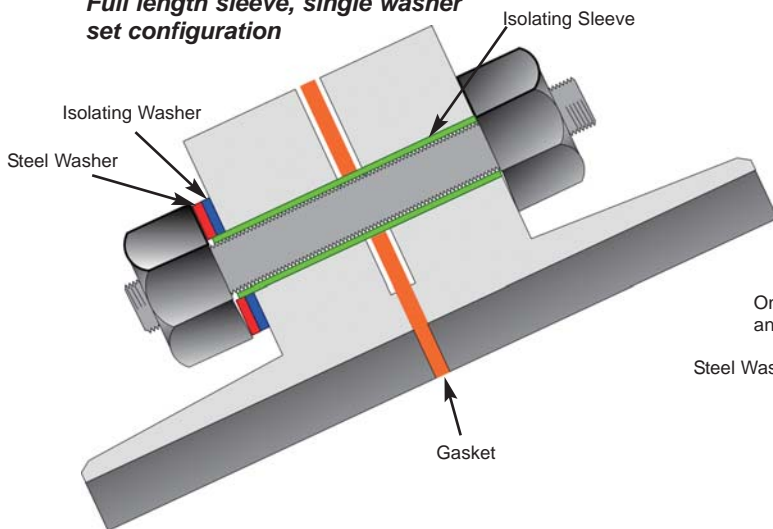

**One-piece sleeve & washer configuration**

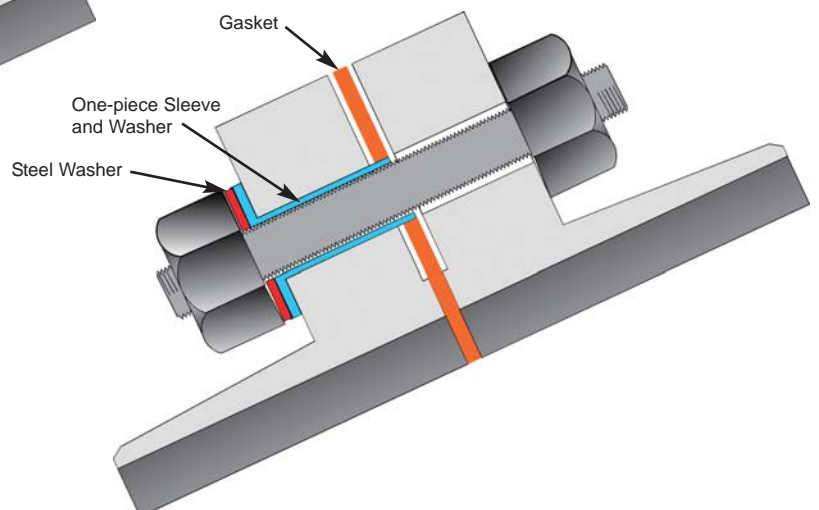

# Flange Isolation Kits

## Flange Isolation Kits

Flange isolation kits are available for all flange sizes, types, pressure ratings and materials. Each kit is individually and securely packed in a reinforced corrugated cardboard box, which is clearly labeled as to its contents for convenience in warehousing and field use. Very large diameter gaskets are packaged separately from the sleeves and washers for convenience in storing and handling.

Each gasket is labeled with:

- Materials (Retainer Material or Retainer/Seal Element Combination)
- Pipe Size
- ANSI Class
- Date of Manufacture
- Type Flange (Weld Neck or Slip-on)

## Sleeves and Washers

Sleeves and washers are enclosed in a strong polyethylene bag to eliminate any possibility of loss. A chart showing the recommended sequence for tightening flange bolts is also included with each kit, as well as with each individual gasket.



## Common LineBacker® & GasketSeal® Sealing Gasket Physical Properties

| ASTM | Test Method                                | Plain Phenolic | Rubber Faced Phenolic | G-3 Hi-Temp Phenolic Glass | G-7* Silicone Glass | G-10 Epoxy Glass  | G-11 Epoxy Glass  |
|------|--|----------------|-----------------------|----------------------------|---------------------|-------------------|-------------------|
| D149 | Dielectric Strength Volts/Mil (Short Time) | 500            | 500                   | 550                        | 350-400             | 550               | 550               |
| D695 | Compressive Strength (psi)                 | 25,000         | 25,000                | 50,000                     | 40,000              | 50,000            | 50,000+           |
| D229 | Water Absorption (%)                       | 1.6            | 1.6                   | 0.7                        | 0.07                | 0.10              | 0.10              |
| D257 | Insulation Resistance Meg Ohms             | 40,000         | 40,000                | 46,000                     | 2,500               | 200,000           | 200,000           |
| D790 | Flexural Strength (psi)                    | 22,500         | 22,500                | 60,000                     | 27,000              | 60,000            | 75,000+           |
| D785 | Hardness Rockwell "M"                      | 85             | 85                    | 115                        | 105                 | 115               | 115               |
| D256 | IZOD Impact Strength (Ft-Lbs/Inch)         | 1.2            | 1.2                   | 12.0                       | 8.0                 | 14.0              | 12.0              |
| D638 | Tensile Strength (psi)                     | 20,000         | 20,000                | 42,000                     | 25,000              | 45,000            | 43,000            |
| D732 | Shear Strength (psi)                       | 10,000         | 10,000                | 18,000                     | 20,000              | 22,000            | 22,000            |
|      | Temperature Range (Degrees F)              | -65 to +220    | -65 to +175           | -65 to +392                | Cryogenic to +450   | Cryogenic to +280 | Cryogenic to +349 |
|      | Temperature Range (Degrees C)              | -54 to +104    | -54 to +79            | -54 to +200                | Cryogenic to +232   | Cryogenic to 138  | Cryogenic to +176 |

\* = G-7 Material should not be used with hydrocarbons, not even trace amounts.

## Seal Element Temperature Limits

|                    | Nitrile     | Viton       | Teflon            | Neoprene    | EPDM        |
|--------------------|-------------|-------------|-------------------|-------------|-------------|
| Degrees Fahrenheit | -40 to +250 | -20 to +350 | Cryogenic to +450 | -40 to +175 | -65 to +300 |
| Degrees Celsius    | -40 to +121 | -29 to +177 | Cryogenic to +232 | -40 to +79  | -54 to +149 |

Consider **both** retainer and seal element temperature limits together for GasketSeal® and LineBacker® Sealing Gaskets.

# Flange Isolation Kits

## Single Washer Set

Single washer set flange isolation kits include the following items for each bolt:

One - 1/8" thick steel washer

One - Isolating washer

One - Isolating sleeve

### Application Considerations

In buried applications, single washer configurations may be used to allow the Cathodic Protection (CP) current to reach the nuts and bolts. If desired, nuts on the opposite side of the cathodically protected flange may be included as part of the CP system.

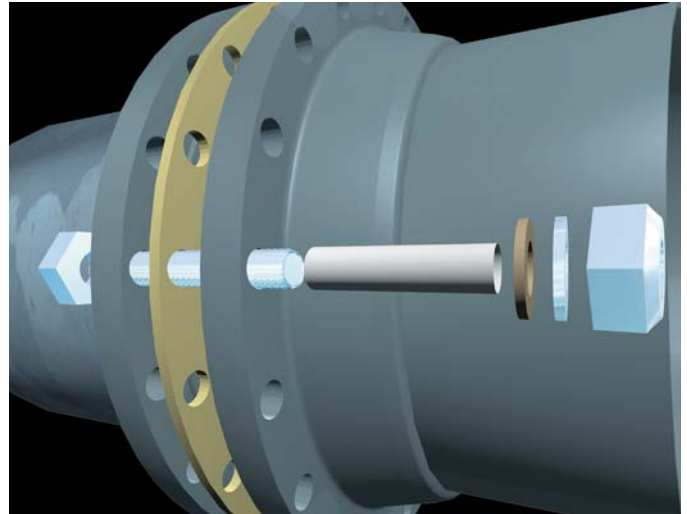

## Double Washer Set

Double washer set flange isolation kits include the following components for each bolt:

Two - 1/8" thick steel washers

Two - Isolating washers

One - Full length isolating sleeve

### Application Considerations

Double washer configurations may be used for added protection against the possibility of "shorting out" the nuts and bolts. In addition, double washer sets electrically isolate the nuts and bolts from both flanges.

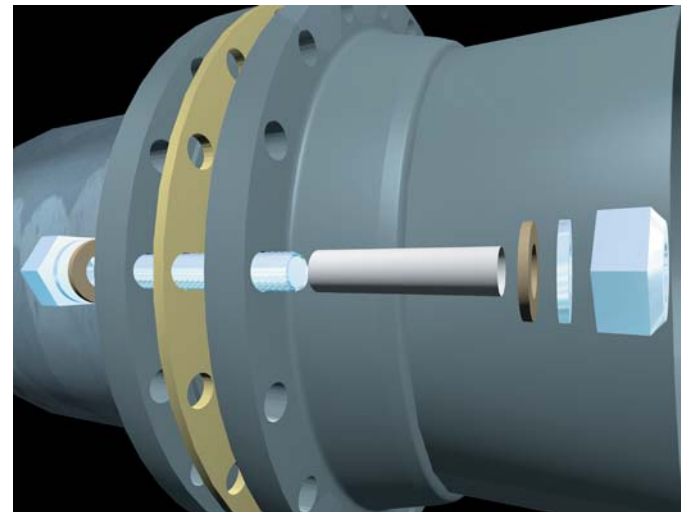

## One-Piece Sleeve and Washer Sets

One-piece sleeve and washer set flange isolation kits include the following items for each bolt:

Two - 1/8" thick steel washers

One - One-piece Isolating sleeve

### Application Considerations

Easier to install, one-piece sleeves also allow the inspector a visual indication of sleeve usage. Due to the relatively low compressive strength of this material, its use is not recommended for high pressure or large diameter flanges that require high torque loads.

**Note:** G-10 One-Piece sleeve/washer assembly available for additional strength and convenience. See page 6 photo.

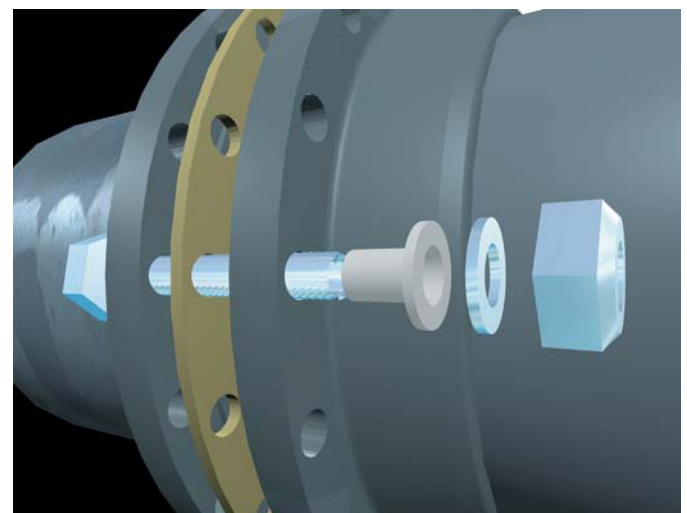

**Buried Application Note:** Consider using the ElectroStop monolithic isolation fitting.

# Typical Specifications

## General/Economical

---

### Flange Isolation Kit Specification

Materials for flange isolation kits on pipes containing water, aqueous fluids or natural gas (up to 220°F, 104°C) shall consist of the following components:

#### Isolating and Sealing Gasket

One full faced isolating and sealing gasket, LineBacker® Sealing Gasket - Type "E", 1/8" thick, phenolic retainer containing a precision tapered groove to accommodate the controlled compression of a EPDM quad-ring sealing element. Sealing element placement shall accommodate either flat, raised or RTJ face flanges. The quad-ring seal shall be pressure energized. The phenolic retainer shall have a 500 volts/mil dielectric strength and a minimum 25,000 psi compressive strength. The full faced flange isolating gasket shall be 1/8" less in I.D. than the I.D. of the flange in which it is installed.

#### Full Length Bolt Isolating Sleeves

One full length Mylar sleeve (extending half way into both steel washers) for each flange bolt. The Mylar shall be a 1/32 inch thick tube with a 4000 volts/mil dielectric strength and water absorption of 0.8% or less.

### Washers

Two, 1/8 inch thick, glass clad phenolic isolating washers for each bolt. Their compressive strength shall be 33,000 psi, dielectric strength 500 volts/mil and water absorption 1.6% or less.

Two, 1/8 inch thick steel washers for each bolt. The I.D. of all washers shall fit over the isolating sleeve and the steel and isolating washers shall have the same I.D. and O.D.

#### Quality

Flange isolating kits shall be manufactured at a facility that has a registered ISO 9001:2000 Quality Management System. Submittals shall include copy of valid registration.

#### Availability

Kits shall be manufactured by Pipeline Seal and Insulator, Inc., Houston, Texas, U.S.A., Telephone: 713-747-6948, Facsimile: 713-747-6029, [www.pipeline-seal.com](http://www.pipeline-seal.com). e-mail: [info@psipsi.com](mailto:info@psipsi.com).

Performance suitability and material compatibility shall be determined by the user.

## Top of the Line

---

### Flange Isolation Kit Specification

Materials for flange isolation kits on pipes containing natural gas, oil and aqueous fluids (up to 280°F, 138°C) shall consist of the following components:

#### Isolating and Sealing Gasket

One full faced isolating and sealing gasket, LineBacker® Sealing Gasket - Type "E", 1/8" thick, G-10 retainer containing a precision tapered groove to accommodate the controlled compression of a Teflon (or Viton) quad-ring sealing element. Sealing element placement shall accommodate either flat, raised face or RTJ flanges. The quad-ring seal shall be pressure energized. The G-10 retainer shall have a 550 volts/mil dielectric strength and a minimum 50,000 psi compressive strength. The full faced flange isolating gasket shall be 1/8" less in I.D. than the I.D. of the flange in which it is installed.

#### Full Length Bolt Isolating Sleeves

One full length G-10 sleeve (extending half way into both steel washers) for each flange bolt. The G-10 shall be a 1/32 inch thick tube with a 400 volts/mil dielectric strength and water absorption of 0.10% or less.

### Washers

Two, 1/8 inch thick, G-10 isolating washers for each bolt. Their compressive strength shall be 50,000 psi, dielectric strength 550 volts/mil and water absorption 0.10% or less. Two, 1/8 inch thick zinc plated, hot rolled steel washers for each bolt. The I.D. of all washers shall fit over the isolating sleeve and both the steel and isolating washers shall have a same I.D. and O.D.

#### Quality

Flange isolating kits shall be manufactured at a facility that has a registered ISO 9001:2000 Quality Management System. Submittals shall include copy of valid registration.

#### Availability

Kits shall be manufactured by Pipeline Seal and Insulator, Inc., Houston, Texas, U.S.A., Telephone: 713-747-6948, Facsimile: 713-747-6029, [www.pipeline-seal.com](http://www.pipeline-seal.com). e-mail: [info@psipsi.com](mailto:info@psipsi.com).

Performance suitability and material compatibility shall be determined by the user.

## PSI Flange Isolation Ordering Guide/Work Sheet

| Quantity         | Nominal Pipe Size | ANSI Class   | Gasket Type  | Gasket Style   | For GasketSeal® or LineBacker® Sealing Gaskets     | Washers  | Washer Material                                | Sleeve   | Gasket I.D. Flange  | Type   |
|------------------|-------------------|--|--|--|--|--|--|--|---|--|
| Specify<br>Below | Specify<br>Below  | 150#<br>300#<br>400#<br>600#<br>900#<br>1500#<br>2500# | E = With Bolt Holes<br><br>F = Ring (No Bolt Holes)<br><br>D = For RTJ Flanges | GS = GasketSeal®<br>LB = LineBacker®<br>NP = Rubber<br><br>PP = Plain<br>RD = Red Devil<br>YJ = Yellow Jacket<br>GL = Garlock<br>TF = Teflon®<br>D = Phenolic D Ring | Retainer<br>Phenolic<br>G-3<br>G-7<br>G-10<br>G-11 | Seal Element<br>Neoprene<br>Nitrile<br>Viton<br>EPDM<br>Teflon (LB only) | SW = Single Washers<br><br>DW = Double Washers | 1 PC = 1 Piece Acetal<br>Phen = Phenolic<br>G-3<br>G-7<br>G-10<br>G-11 | Poly = Poly-ethylene<br>Mylar<br>Nomex<br>Phenolic<br>G-7<br>G-10<br>G-11 | Specify Below<br><br>W = Weld Neck<br>S = Slip On<br>R = RTJ<br>BX = API BX<br>RX = API RX<br>O = Other<br>Denote Specs. and Table |

| Quantity | Nominal Pipe Size | ANSI Class | Gasket Type | Gasket Style | For GasketSeal® or LineBacker® Sealing Gaskets | Washers | Washer Material | Sleeve | Gasket I.D. Flange | Type |
|----------|-------------------|------------|-------------|--------------|--|---------|-----------------|--------|--------------------|------|
|          |                   |            |             |              | Retainer    Seal Element                       |         |                 |        |                    |      |
|          |                   |            |             |              |  |         |                 |        |                    |      |
|          |                   |            |             |              |  |         |                 |        |                    |      |
|          |                   |            |             |              |  |         |                 |        |                    |      |
|          |                   |            |             |              |  |         |                 |        |                    |      |

**For Flange Isolation Kits over 24" in addition to the above please specify:**



**Flange Facing**

(Raised, RTJ..etc)

Flange I.D.

Flange O.D.

Flange Thickness

Number of Studs/Bolts

Stud/Bolt Diameter

Stud/Bolt Hole Diameter

Stud/Bolt Circle Diameter

**Nominal Bolt Diameter**

(Threads/Inch)

Sleeve Length

Pipe I.D.

Steel Sleeve I.D.  
(For Concrete Pipe)

Product In Line

AWWA Class & Table  
(Or other similar std.)

Internal Lining

**Note: Caution! Bolts with smooth shank portions may not fit within sleeves. Verify prior to ordering.**

## Warranty

All products are warranted against failure caused by manufacturing defects for a period of one year. Any product found to be so defective and returned within one year from date of shipment will be replaced without charge.

The above warranty is made in lieu of, and we disclaim, any and all other warranties, expressed or implied, including the warranties of merchantability and fitness for a particular purpose, and buyer agrees to accept the products without any such warranties.

We hereby disclaim any obligation or liability for consequential damages, labor costs or any other claims or liabilities of any kind whatsoever.

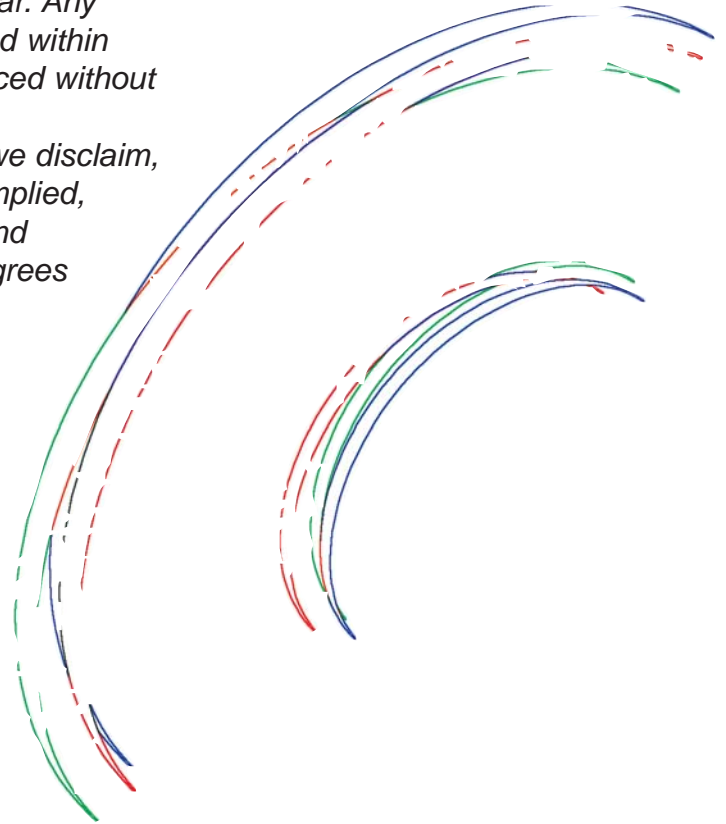

## ElectroStop Monolithic Isolation Fittings...Alternative to Flange Isolation Kits.

The ElectroStop™ monolithic isolation fitting will serve as a positive leak proof, long lasting block against the flow of electric current in all piping systems.

When you bury the ElectroStop isolation fitting you bury maintenance costs forever - an especially important feature for system operators and engineers.



## The Industry's "Dual 'O' Ring Seal"

Standard Test Include:

100% Hydrostatic Pressure & Electrical tests

100% Ultrasonic of Welds

100% Magnetic Particle of Welds

100% Dye Penetrant of Welds



## Pipeline Seal and Insulator, Inc.

6525 Goforth Street, Houston, TX 77021 U.S.A.

Telephone: 713-747-6948 • Toll Free: 800-423-2410 • Facsimile: 713-747-6029

www.pipelinesseal.com • e-mail: info@psipsi.com



Certificate No. NACB7895



Certificate No. 10125

©2007 - Pipeline Seal and Insulator, Inc.

PSI-FIC-1/07

The foregoing performance data are intended as guidelines only. Performance suitability for any specific applications should be determined by the user. Variation in temperature, pressure, concentration or mixtures acting synergistically may preclude suggested service use. Material selection is at the sole risk of the user. Consult with a specialist or PSI factory for specific applications. PSI's responsibilities will be limited to those listed in the PSI standard warranties. Note: Graphics not to scale, for illustration use only.